

Instructions: You have a total of 55 minutes to complete this test.

Answer each question completely showing complete details.

For complete credit you must include correct SI units with numerical answers.

Time Start _____ Time finish _____ pledged _____

Constants: $k=8.987 \times 10^9 \frac{\text{Nm}^2}{\text{C}^2}$; $\epsilon_0=8.854 \times 10^{-12} \frac{\text{C}^2}{\text{Nm}^2}$; $\mu_0=4\pi \times 10^{-7} \frac{\text{T}}{\text{mA}}$

[1] Consider a parallel plate capacitor with plates of area A separated by a distance d as shown. You may assume this to be an infinite parallel plate capacitor. The surface charge density at $x=0$ is $+\sigma$ and the surface charge density at $x=d$ is $-\sigma$ as shown.

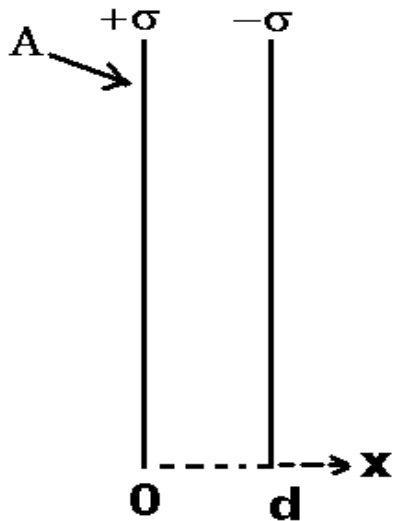

(a) Sketch the vector electric field for the following regions: ($x < 0$), ($0 < x < d$) and ($x > d$) on the diagram.

(b) Showing complete details and assumptions (using sketches as needed), calculate the vector electric field inside the capacitor. You must show full details here for credit. Your answer involves σ and ϵ_0 .

(c) The capacitance of the parallel plate capacitor is given by $C = \epsilon_0 \frac{A}{d}$. Suppose the separation of the plates is $d=0.1$ m and the area of the plates is $A=1$ m². If the potential difference between the plates is $V=10$ V, find the energy density together with correct SI units inside the capacitor.

(d) Suppose in a region of space, the potential is given by $V=5x$. Find the **vector** electric field in this region.

[2] A wire of radius a carries a uniform current density given by $\vec{j} = |j| \hat{z}$ which is directed out of the page as shown. The wire carries a total current I .

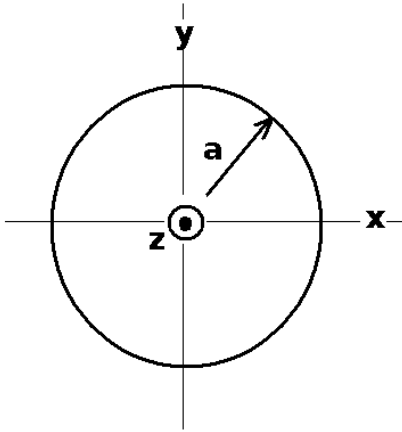

(a) Which direction does the magnetic field circulate around the wire? (circle the correct answer below).

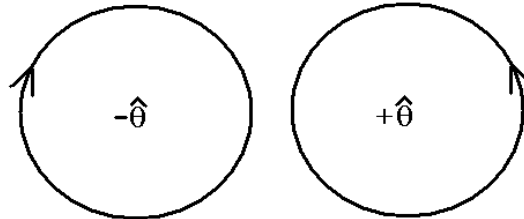

(b) Calculate the magnitude of the current density in terms of I and a .

(c) Showing complete details, including sketches as necessary, calculate the vector magnetic field inside the wire in terms of I , a and the radius vector r .

(d) Showing complete details, including sketches as necessary, calculate the vector magnetic field outside the wire in terms of I , and the radius vector r .

(e) Suppose $I=1$ A and $a=0.1$ m. Find the magnitude of the magnetic field at the surface of the wire with correct SI units.

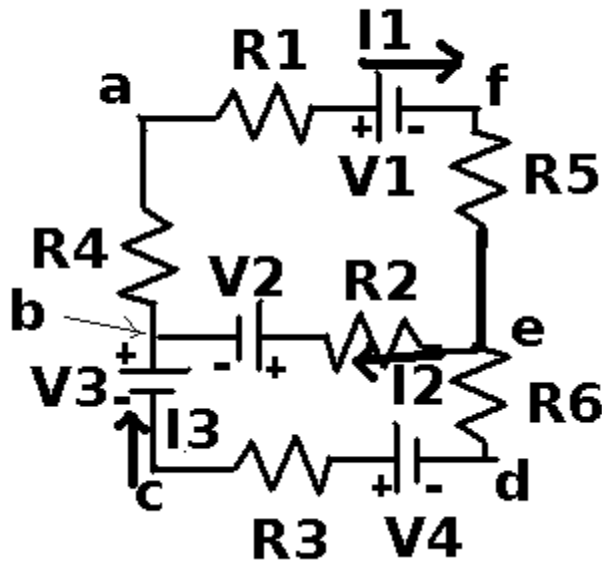

[3] Consider the circuit shown to the left.

(a) Provide the Kirchoff's laws equations for the following loops and junction:

(afeba):

(bedcb):

@e:

(b) Suppose for the following values: $(R_1, R_2, R_3, R_4, R_5, R_6) = (1, 2, 3, 4, 5, 6)\Omega$
and for the following voltages: $(V_1, V_2, V_3, V_4) = (1, 2, 3, 4)V$
the following currents result: $I_1 = -.118A$, $I_2 = -.914A$, $I_3 = .797A$.

Calculate the total power dissipated in the circuit (with correct SI units).

(c) What is the interpretation for the value of the current I_2 ?

[4] Note: be sure to include correct SI units with your answers below.

(a) Graphite has a resistivity of $7.84 \times 10^{-6} \Omega \cdot \text{m}$. What is the resistance of a 1 m long graphite rod of cross sectional area $A = 0.01 \text{m}^2$ in the shape of a cylinder across the ends?

(b) Graphite has a dielectric constant of about 15. What is the capacitance of a rectangular piece of graphite of area $A = 0.1 \text{m}^2$ and thickness $d = 0.01 \text{m}$?

(c) If a 300Ω resistor is placed in series with a 600Ω resistor, what is the equivalent resistance?

(d) If a 300Ω resistor is placed in parallel with a 600Ω resistor, what is the equivalent resistance?

(e) If a $4 \mu\text{f}$ capacitor is placed in series with a $6 \mu\text{f}$ capacitor, what is the equivalent capacitance?

(f) If a $4 \mu\text{f}$ capacitor is placed in parallel with a $6 \mu\text{f}$ capacitor, what is the equivalent capacitance?